



pressure safety valves

TYPE	CODE NR	CONNECTION DIA.	L1 (mm)	L2 (mm)
PRD - 25	43101 (Short Spring)	R1 "	88	31
PRD - 25 - L	41101 (Long Spring)	R1 "	144	87

APPLICATION

The PRD - 25 pressure safety valve is employed as a safety element in distribution transformers of low rating. In the event of an explosion-type pressure increase of the transformer tank, the excess pressure must be relieved immediately in order to avoid damage to the tank.

These types are suitable for hermetically sealed type transformers

CONSTRUCTION

The PRD - 25 pressure safety valve consists of a brass cap, a conical valve body, a rubber seal between the cap and body and a coil spring holding the whole system. As soon as relief pressure is reached, the valve cap lifts off and the excess pressure is relieved.

The valve then shuts itself down again automatically.

The valve can be infinitely set from 0.2 to 0.7 bar.

The valve can also be equipped with a specially manufactured protective cap to prevent unauthorized operation of valve.

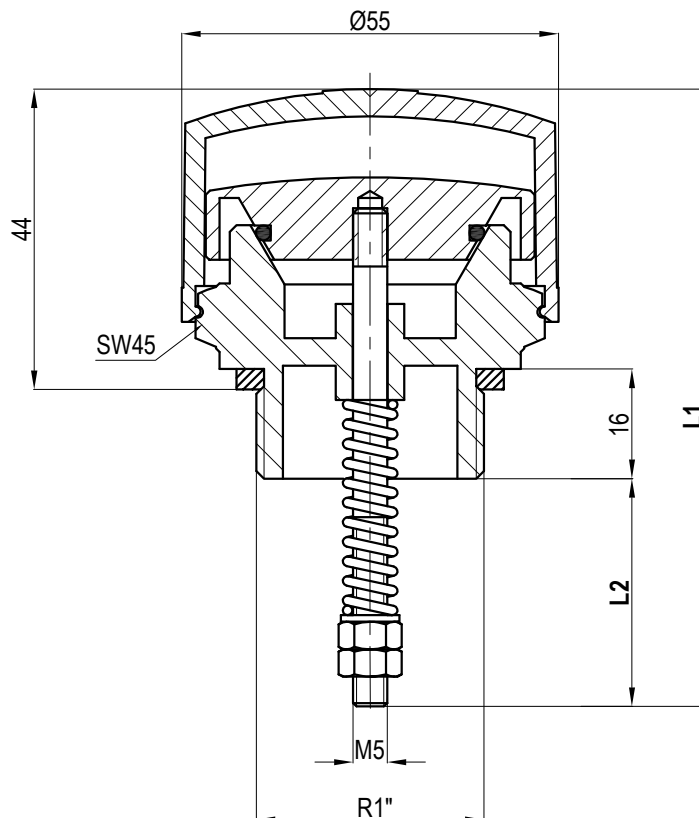
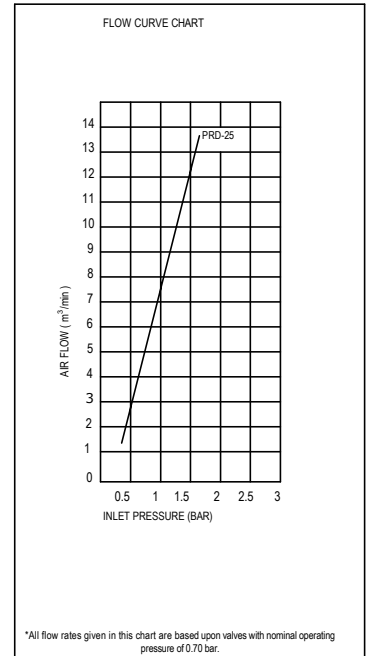
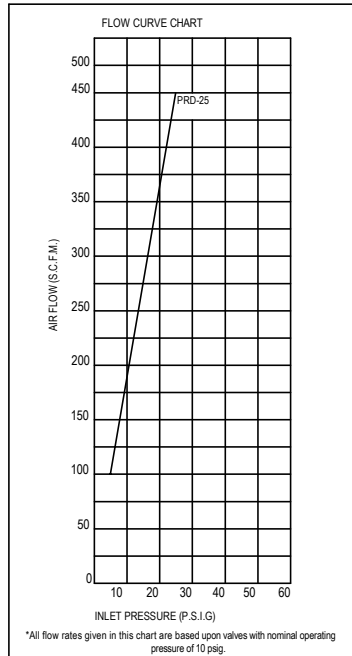

TYPE	CODE NR	CONNECTION DIA.	L1 (mm)	L2 (mm)
PRD - 50	44104 (Short Spring)	R2 "	88	31
PRD - 50 - L	44504 (Long Spring)	R2 "	144	87

APPLICATION

The PRD - 50 pressure safety valve is employed as a safety element in distribution transformers of low rating. In the event of an explosion-type pressure increase of the transformer tank, the excess pressure must be relieved immediately in order to avoid damage to the tank.

These types are suitable for hermetically sealed type transformers

CONSTRUCTION

The PRD - 50 pressure safety valve consists of a brass cap, a conical valve body, a rubber seal between the cap and body and a coil spring holding the whole system. As soon as relief pressure is reached, the valve cap lifts off and the excess pressure is relieved.

The valve then shuts itself down again automatically.

The valve can be infinitely set from 0.2 to 0.7 bar.

The valve can also be equipped with a specially manufactured protective cap to prevent unauthorized operation of valve

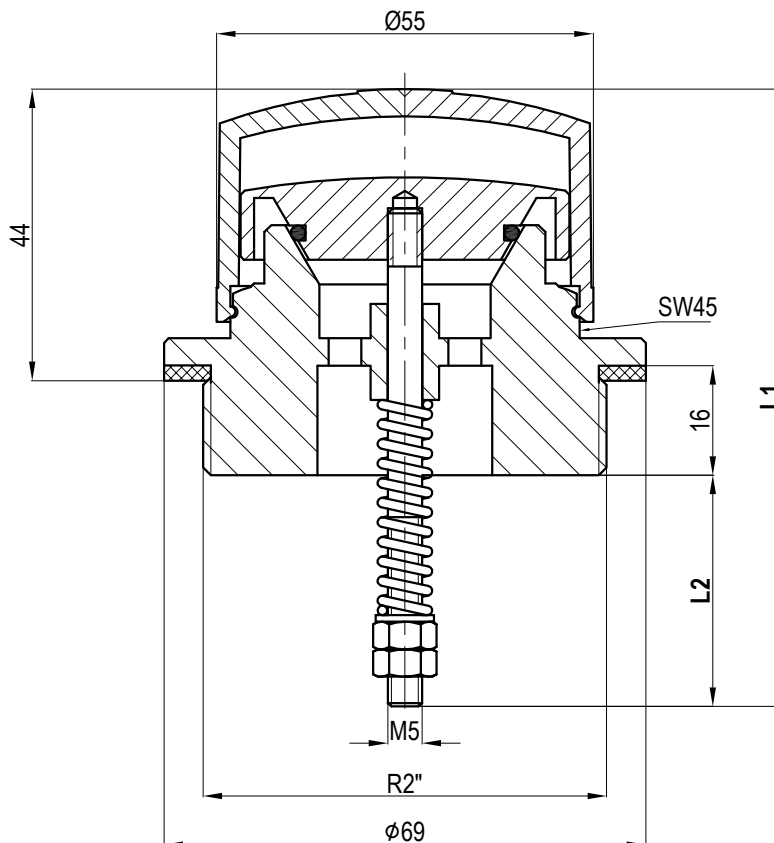
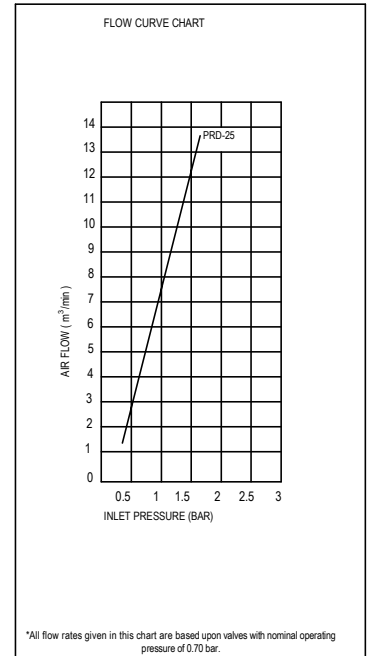
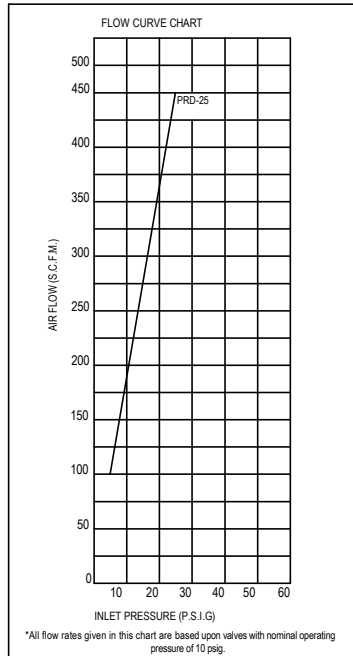

TYPE	CODE NO	CONNECTION DIA.
PRD - 10	401	1/2" NPT

DESCRIPTION

This type of Pressure Relief Valves features a one-piece brass housing. A stainless steel spring, factory selected to a predetermined rating, is designed to release pressure build-up from within a sealed tank. A rubber O'ring seals the valve.

There is a stainless steel pull ring attached to the valve shaft to allow for manual operation.

These valves are designed to operate under environmental conditions encountered on outdoor applications. The exhaust port is protected by a "bug shield" cover which inhibits foreign matter from entering the valve body. The valve setting is stamped on the "bug shield" for fast and easy identification.

These types are suitable hermetically sealed type transformers

OPERATION

When gas pressure in the tank exceeds a specified limit, the valve automatically compresses the spring and drives the poppet, breaking the seal and venting potentially dangerous pressure. With the pressure reduced the valve automatically reseals itself to prevent entry of outside air.

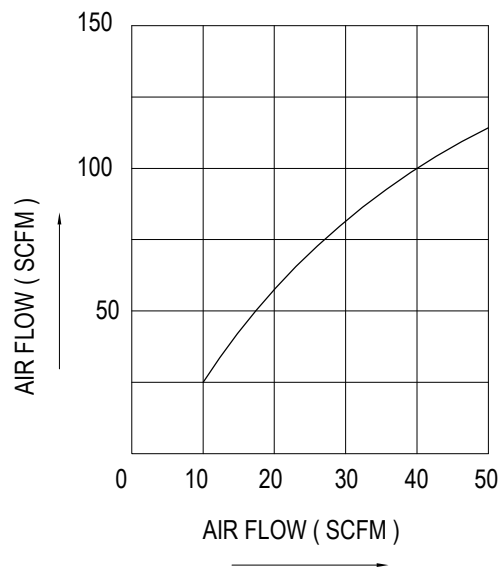
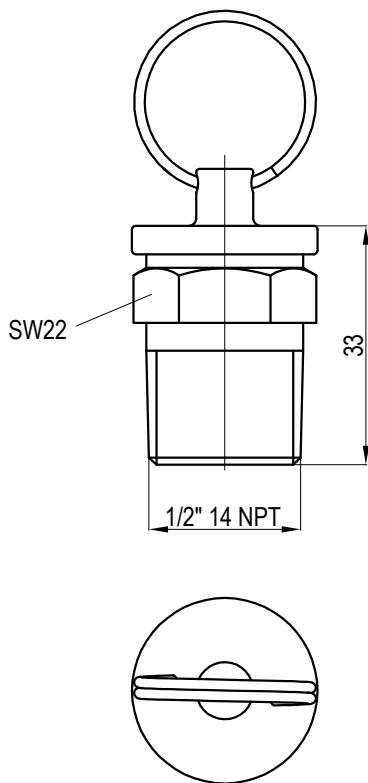

TE TAMAM ELEKTRİK



TAMAM Elektrik Sanayi ve Ticaret A.S.

Tepeoren ITOSB Mah. 9. Sokak No. 20, Tuzla - İstanbul / TÜRKİYE
Tel : +90 - 216 - 504 17 66 Fax : +90 - 216 - 515 64 18
Email : info@tamamelektrik.com.tr Website : www.tamamelektrik.com.tr